

Rewind™ Radial® Electric Winch

The Radial Rewind electric winch is the latest in Harken's "easy sailing" solutions for cruisers, and the first winch of its kind in the marine market. Activated remotely by twin in/out buttons, the Radial Rewind lets you safely ease and trim highly loaded sails in both directions without ever taking the line out of the self-tailer, a patented feature.

Whether you solo or are passaging with friends, the Rewind will make your cruise relaxing and fun, allowing both you and your guests to take pleasure in the sea's beauty instead of hauling line and cranking winches.

Like all electric Radials, the Rewind operates like a normal Harken two-speed electric winch. A simple flip of the red knob on the winch base turns on the rewind feature. A spring-loaded arm of investment cast stainless steel funnels and keeps line captive as it feeds in and out of the self-tailer while you adjust the sail under fingertip control.

Available in aluminum, 12-volt horizontal motor only.



A Harken® locking handle inserted into an unloaded winch automatically disconnects the motor gear for manual operation



Activated remotely by twin in/out buttons, the Radial Rewind lets you safely ease and trim highly-loaded sails in both directions without ever taking the line out of the self-tailer



A simple flip of the red knob on the winch base turns on the rewind feature

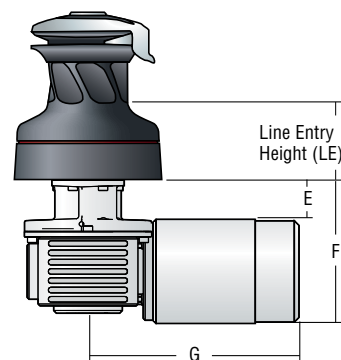

Part No.	Line entry height (LE)		E		F		G	
	in	mm	in	mm	in	mm	in	mm
46RWA	3 ⁹ / ₁₆	90	1 ³ / ₄	43	6 ¹ / ₈	155	11	280

Part No.	Drum		Base		Height (H)		Weight		Line Ø (Min - Max)		Fastener circle		Fasteners (SH or HH)		Gear ratio		Power ratio	
	in	mm	in	mm	in	mm	lb	kg	in	mm	in	mm	in	mm	1	2	1	2
46RWA	3 ⁷ / ₈	100	7 ¹ / ₄	184	8	203	35.3	16	3 ⁷ / ₈ - 9 ¹ / ₁₆	10 - 14	5 ⁷ / ₈	150	5 x 5 ¹ / ₁₆	5 x 8	2.3	9.17	11.7	46.5

Kit: see page 184 (available in USA only)